

Vandal Resistant Series

Medium Vandal Resistant Fixture HID & Fluorescent



**VN30,
VN30HF42EL**

Housing:

Die Cast Aluminum Housing, 1/2" Coin Plugs with O-rings for Conduit & Photocell on Two Sides & Back, Textured Architectural Bronze Powdercoat Finish Over a Chromate Conversion Coating

Reflector:

White Powdercoat Steel Reflector

Lens:

Clear Prismatic Polycarbonate Lens

Socket:

VN30: Porcelain 4KV Pulse Rated Mogul Base Socket with Nickel Plated Screw Shell

VN30HF: Plug-In Type, GX24Q-4

Mounting:

Mount Directly Over a Recessed Electrical Box or use 1/2" Surface Conduit.

Wattage:

High Pressure Sodium: 35 to 70w

Metal Halide: 35 to 70w

Compact Fluorescent: 1 x 26 to 42w

Listings & Ratings:

CSA: Listed for Wet Locations

Access Fixtures

| Kit(s) | | | | |
|---------------------------------|--|---------|------|------------|
| Catalog # | Description | | | |
| VN30 | Medium Vandal Resistant HID Kit | | | |
| VN30HF | Medium Vandal Resistant Single Fluorescent Kit | | | |
| Complete Units (Lamps Included) | | | | |
| Catalog # | Wattage | Voltage | Lamp | Ballast |
| VN30H35R120L | 35 | 120 | HPS | R-NPF |
| VN30H50R120L | 50 | 120 | HPS | R-NPF |
| VN30H70R120L | 70 | 120 | HPS | R-NPF |
| VN30H50DL | 50 | 120/277 | HPS | HX-HPF |
| VN30H70QL | 70 | Quad | HPS | HX-HPF |
| VN30M35DL | 35 | 120/277 | MH | HX-HPF |
| VN30M50DL | 50 | 120/277 | MH | HX-HPF |
| VN30M70QL | 70 | Quad | MH | HX-HPF |
| VN30HF26EL | 1 x 26 | 120-277 | PL | Electronic |
| VN30HF32EL | 1 x 32 | 120-277 | PL | Electronic |
| VN30HF42EL | 1 x 42 | 120-277 | PL | Electronic |

Add: PC1 120V Photocell (Field Installed)
PC2 208-277V Photocell (Field Installed)
Other Wattages & Custom Colors Available Upon Request.

Dimensions

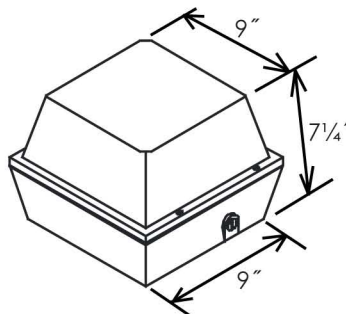

**VN30,
VN30HF42EL**

Access Fixtures
40 Jackson Street
Worcester, MA 01608
888-521-2582
sales@accessfixtures.com
www.AccessFixtures.com

Access Fixtures

Vandal Resistant Series

Medium Vandal Resistant Fixture
HID & Fluorescent

| Catalog # | Description |
|-----------|--------------------------------------|
| VN30PC | Clear Polycarbonate Replacement Lens |
| VN30PW | White Polycarbonate Replacement Lens |

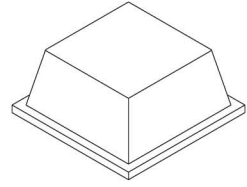

**VN30PC,
VN30PW**

Photometrics

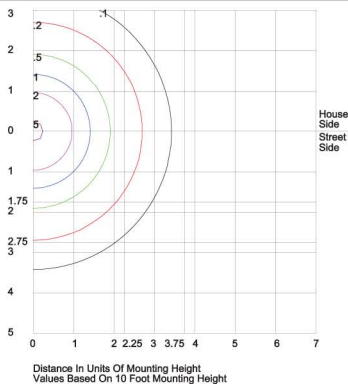

VN30M70

Access Fixtures
40 Jackson Street
Worcester, MA 01608
888-521-2582
sales@accessfixtures.com
www.AccessFixtures.com

Option availability is subject to change without notice.